

<sup>®</sup>  
**CLASS**

## **DS96F-B2**

Drive Axle Rear Suspensions  
for Ford E450 Cutaway Chassis

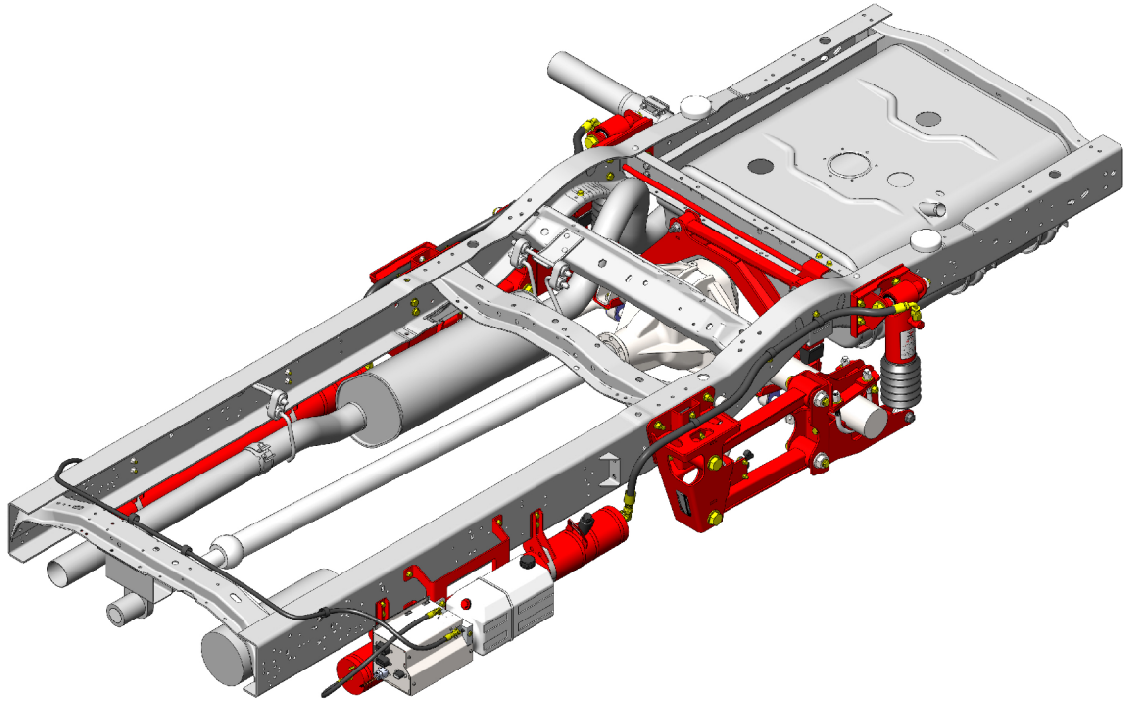

- Non-torque reactive design optimized with CLASS<sup>®</sup>
- Maintains proper driveline geometry through full range of torque inputs reducing driveline noise, vibration, and fatigue
- Variable stiffness and damping adjusted automatically and instantaneously based on road conditions without driver intervention
- Does not require modification to exhaust
- Compact package space claim
- 9600 lbs GAWR for Ford E450 SuperDuty



**Compressible Liquid Adaptive Suspension System**

# DS96F-B2 Drive Axle Rear Suspensions for Ford E450 Cutaway Chassis

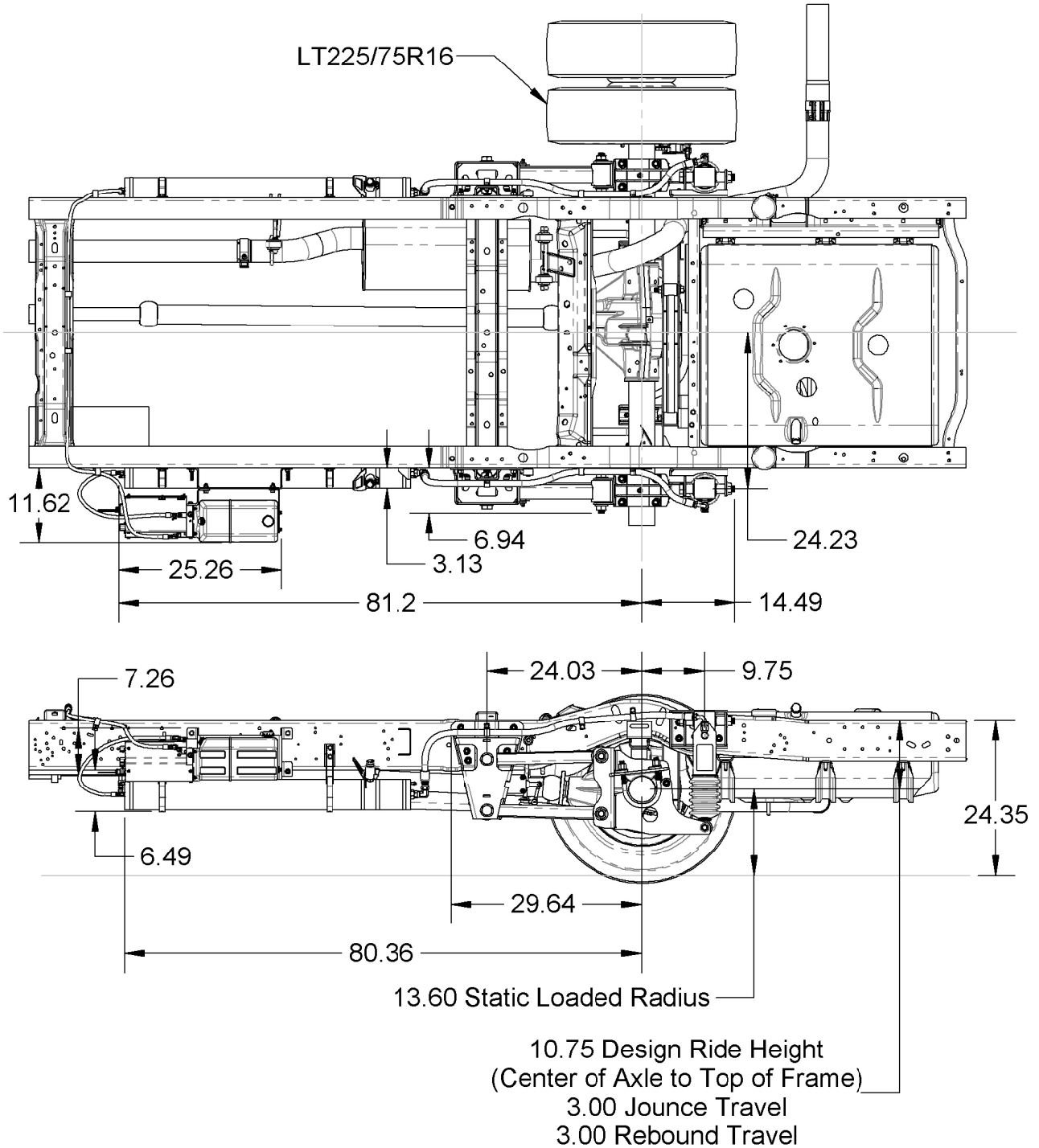

**LiquidSpring™ LLC**

3416 Rascal Drive  
Lafayette, IN 47909

Phone: 765-474-7816

Fax: 765-474-7826

Web: [www.liquidspring.com](http://www.liquidspring.com)